

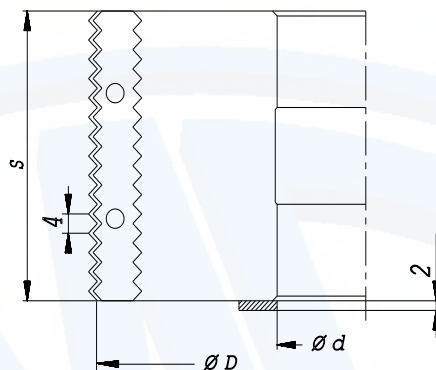
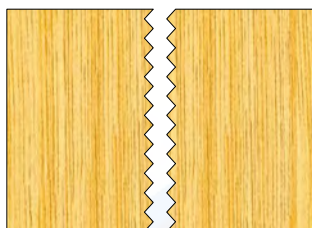

# ART. 450

Fresa per giunzioni passo 4mm con coltelli reversibili

Glue jointing cutter pitch 4mm with reversible knives.

COD.	D mm	d mm	S	Z
45012562	125	30/35 40/50	60	2
45012564	125	30/35 40/50	60	4



Coltelli di ricambio Spare knives	
codice / code	15196001

# ART. 460

Fresa per giunzioni passo 5.6mm con coltelli reversibili

Glue jointing cutter pitch 5.6mm with reversible knives.

COD.	D mm	d mm	S	Z
46012582	125	30/35 40/50	80	2
46012584	125	30/35 40/50	80	4

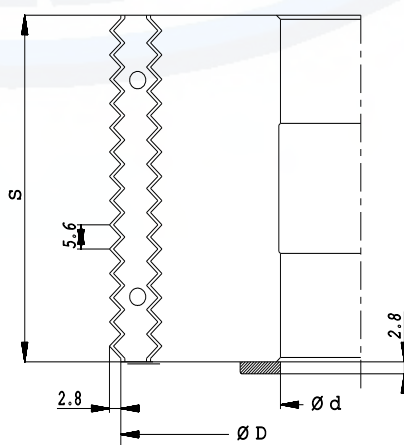
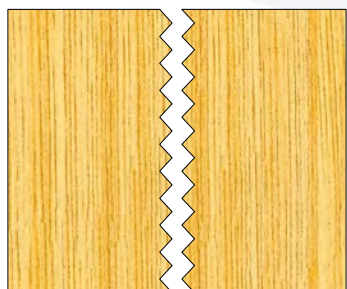

Coltelli di ricambio Spare knives	
codice / code	14196001

# ART. 720

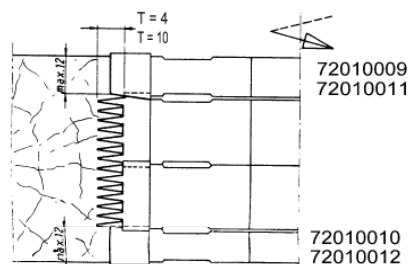
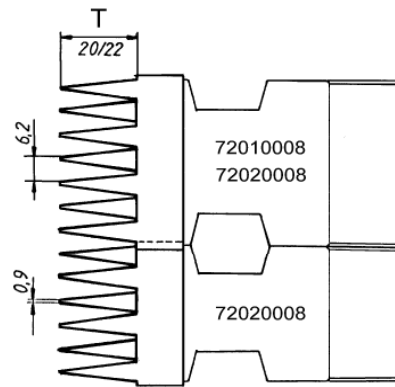
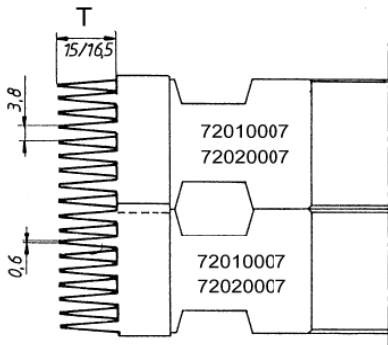
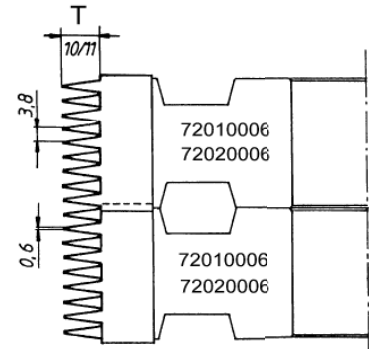
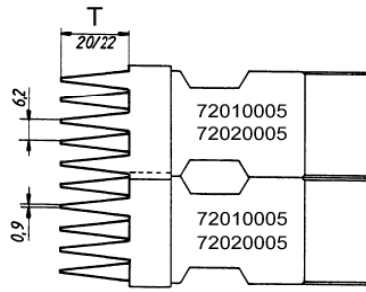
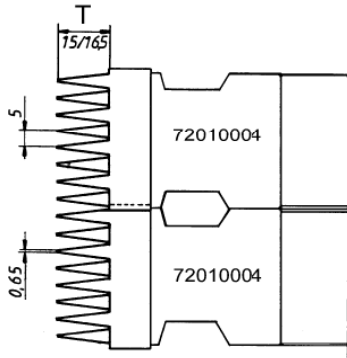
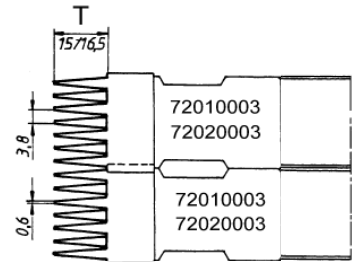
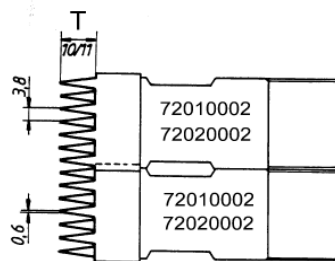
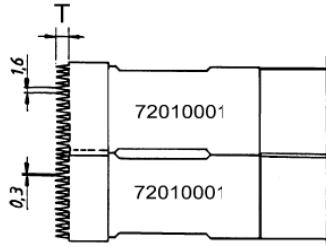



# ART. 510

Utensile per giunzioni a 45° con coltelli in HM

45° jointing cutterhead with knives in HM

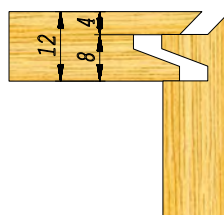
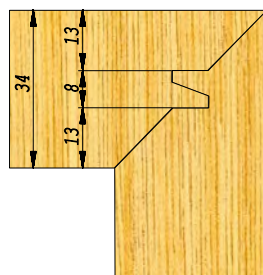
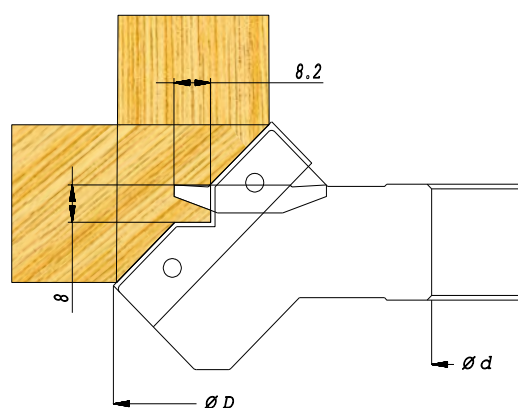
COD.	D mm	d mm	S	Z
51018234	182	30/35 40/50	12-34	2+2

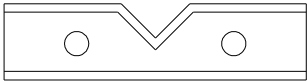

Coltelli di ricambio Spare knives		
codice / code	18106101	191062

# ART. 500

Fresa regolabile per giunzioni passo 6 mm. L'utensile e' composto da due elementi registrabili per mezzo di anelli distanziatori (in dotazione).

Adjustable jointing cutterhead pitch 6 mm. This cutterhead is composed of two elements which can be adjusted by means of spacers (included with the elements).

COD.	D mm	d mm	S	Z
50016682	166	30/35 40/50	20-80	2
50018683	186	30/35 40/50	20-80	3

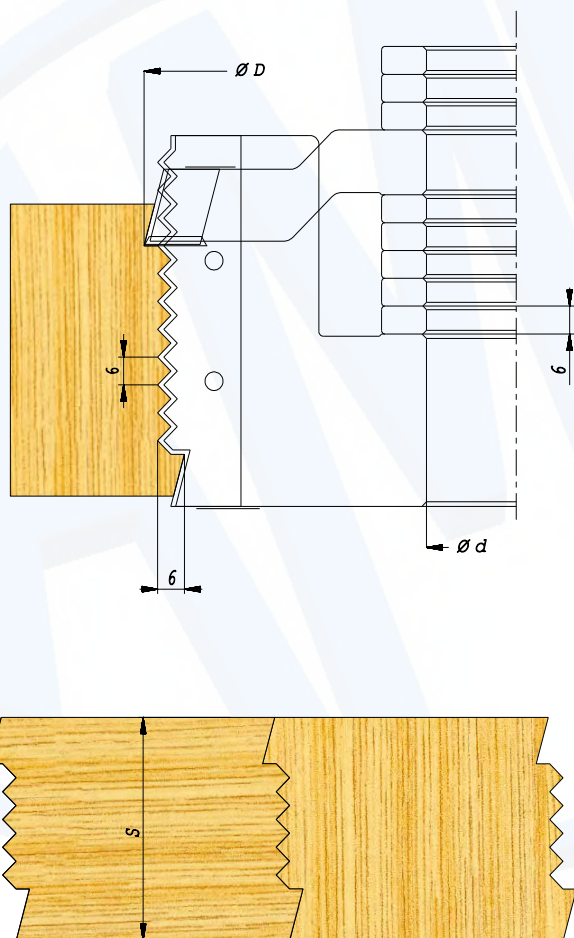

Coltelli di ricambio Spare knives			
codice / code	30916101	12011200 (B)	14140200



# ART. 490

Fresa regolabile per giunzioni passo 8.76mm. L'utensile e' composto da due elementi registrabili per mezzodi anelli distanziatori (in dotazione).

Adjustable jointing cutterhead pitch 8.76mm. This cutterhead is composed of two elements which can be adjusted by means of spacers (included with the elements).

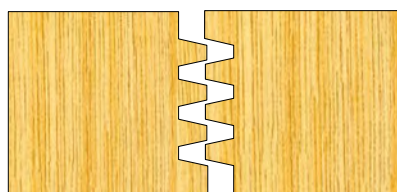
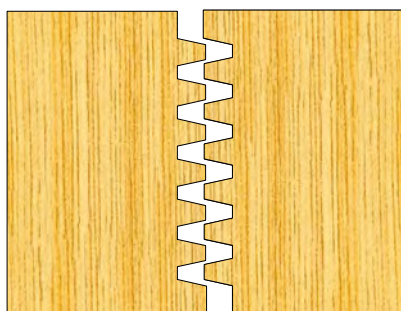
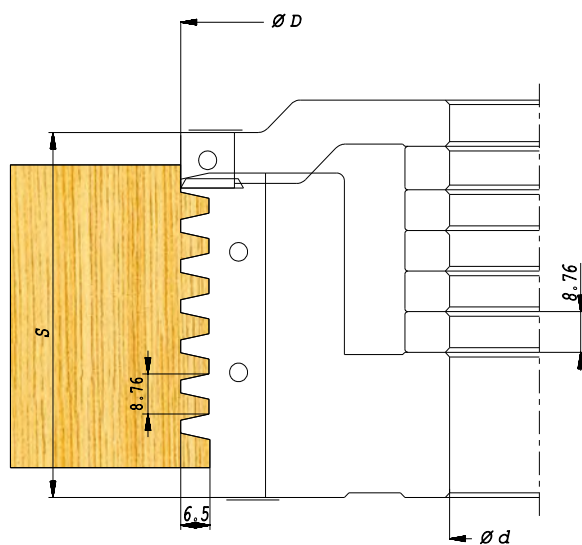
COD.	D mm	d mm	S	Z
49016072	160	30/35 40/50	14-77	2
49018073	180	30/35 40/50	14-77	3

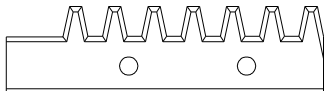

Coltelli di ricambio Spare knives			
codice / code	30421005	12011200 (B)	14140200

# ART. 480

Fresa regolabile per giunzioni passo 7.63mm. L'utensile e' composto da due elementi registrabili per mezzo di anelli distanziatori (in dotazione).

Adjustable jointing cutterhead pitch 7.63mm. This cutterhead is composed of two elements which can be adjusted by means of spacers (included with the elements).

COD.	D mm	d mm	S	Z
48012078	130	30/35 40/50	35-78	2
48012096	130	30/35 40/50	35-96	2
48028078	280	30/35 40/50	35-78	3
48028096	280	30/35 40/50	35-96	3

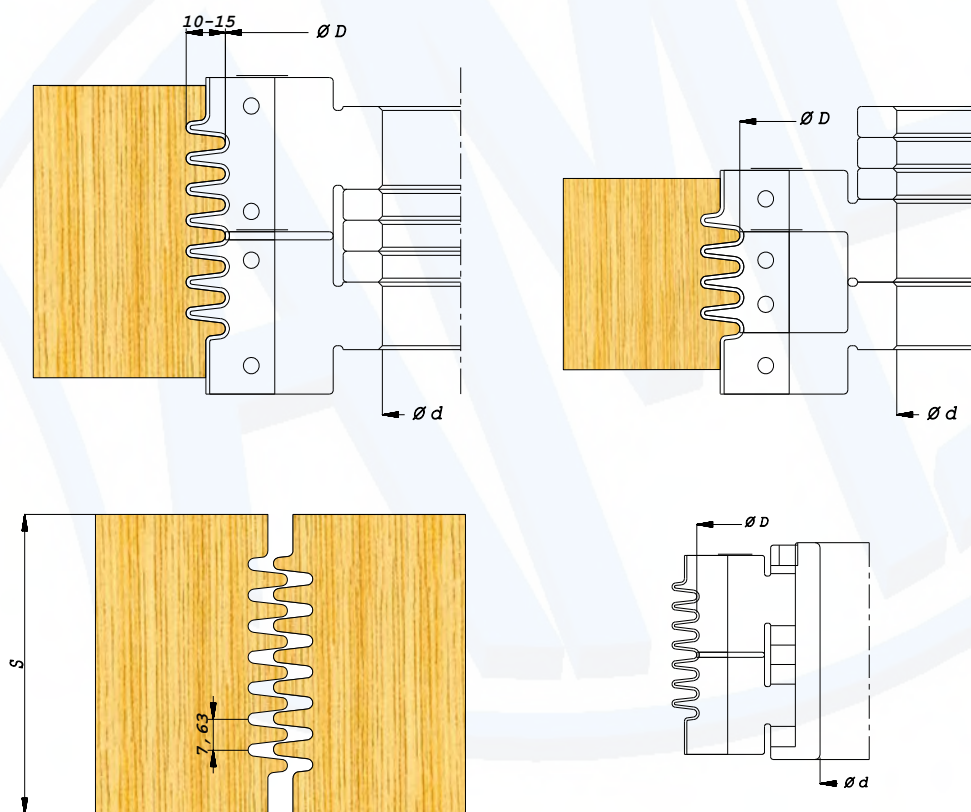

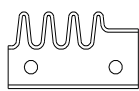
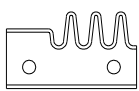
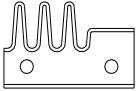
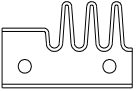
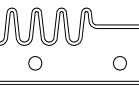
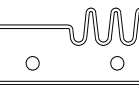
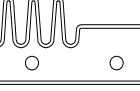
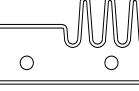
Coltelli di ricambio Spare knives				
codice / code	71023101	71022101	92920005	92919005
Coltelli di ricambio Spare knives				
codice / code	80503101	80502101	92920001	92919001

# ART. 470

Fresa per giunzioni passo 5mm

Glue jointing cutter pitch 5mm

COD.	D mm	d mm	S	Z
47014082	140	30/35 40/50	80	2
47014084	140	30/35 40/50	80	4

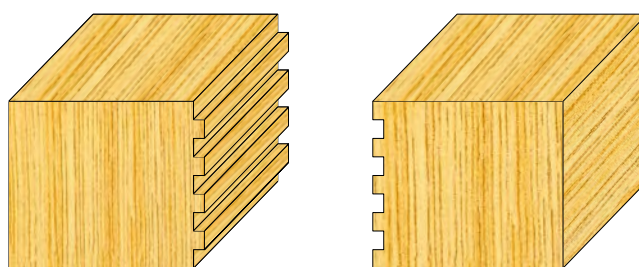
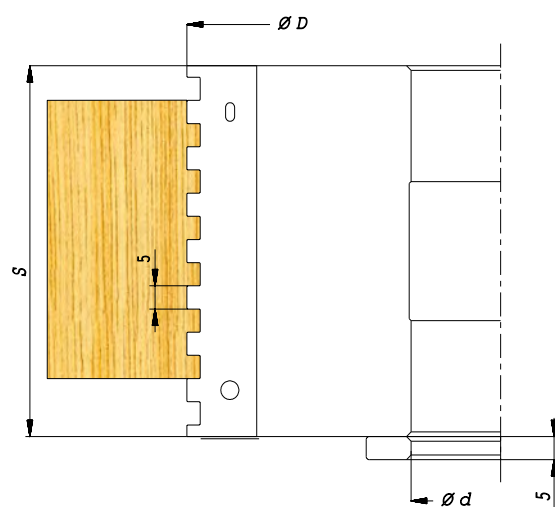

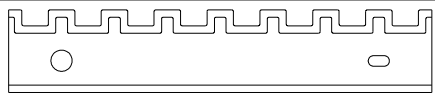
Coltelli di ricambio Spare knives	
codice / code	01004001